



BAR KNOBS

THERMOPLASTIC

Material- Call for material specifications

Insert- Brass

Projecting Stud- Steel, zinc plated

Hex Nut- Steel, zinc plated

† Insert- Steel, zinc plated

* Insert- Aluminum



3081



3084



3088/3089 Thru Hole



3086



3087



3088/3094



3093



3096



2031



2031



2033



2020



2022

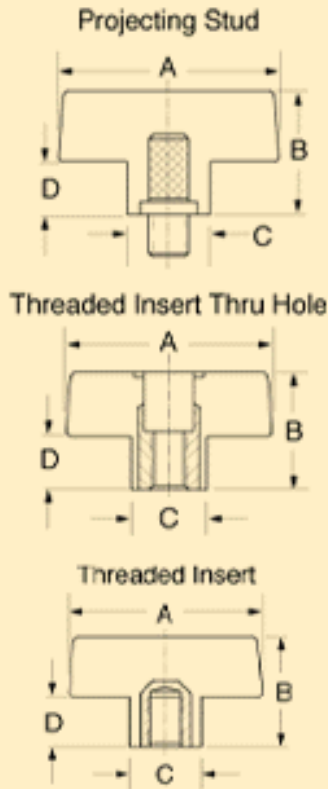

Threaded Insert

Part No.	Insert	
	Thread	Depth
3088-A*	5/16-18	3/4
3088-B	3/8-16	1/2
3088-M	5/16-18	1/2
3088	1/4-20	1/2

Threaded Insert Thru Hole

Part No.	Insert	
	Thread	Depth
3088AS	3/8-16	Hex Nut**
3088AT	5/16-18	Hex Nut**

****Nylok locking feature**

Projecting Stud

Part No.	Stud		Max Length
	Thread	Length	
3088-D	5/16-18	1/2	4-1/2
3088-F	3/8-16	1/2	4-1/2

[← back](#)